

COMMUNITY COLLEGE DISTRICT OF JEFFERSON COUNTY, MISSOURI

REQUEST FOR PROPOSAL: ROOF REPLACEMENT



**Proposal #1904001
Due Date: April 26, 2019
Not later than 2:00 P.M**

**MANDATORY PRE-PROPOSAL
MEETING: April 16, 2019
10:00 A.M.**

**Sheree Bell
Director of Purchasing
636-481-3119
sbell6@jeffco.edu**

**Dale Richardson
Director of
Buildings and Grounds
636-481-3501
drichar6@jeffco.edu**

Request for Proposal

Roof Replacement

Community College District of
Jefferson County
1000 Viking Drive
Hillsboro, MO 63050
Fax # (636) 789-4012

RFP # 1904001
APRIL 4, 2019
Closing Date: April 26, 2019
(NOT LATER THAN 2:00 P.M.)

I. GENERAL CONDITIONS

The Community College District of Jefferson County is requesting proposals to remove and replace the roof on four buildings at the Hillsboro campus. Proposals are to be received on or before **2:00 P.M., April 26, 2019**, at the College Business Office, Attention Sheree Bell, Director of Purchasing. Proposals must be sealed in an envelope and clearly marked on the outside in the lower left-hand corner **“Proposal: Roof Replacement RFP #1904001”**. Failure to comply with this provision of the specification may result in the rejection of the proposal. It is the responsibility of the vendor to confirm the delivery of the proposal at the proper place and time. There will not be exceptions made for proposals delivered late or to the wrong location. **Faxed, emailed, or oral proposals will not be accepted.**

All proposals are to be F.O.B. Jefferson College/prepaid, delivered and be valid for 60 days after closing date. The Community College District of Jefferson County is a public institution and is exempt for all federal, state and local taxes. Do not include any taxes in the quotation. Jefferson College reserves the right to reject any or all proposals in whole or in part and waive any informality.

Proposal award will be made on or about May 9, 2019, and order will be placed immediately thereafter. Successful contractor will be notified of the award and order details will be completed.

There will be a mandatory pre-proposal meeting held on the Hillsboro campus at the Buildings and Grounds facility. The meeting will be held at 10:00 A.M., April 16, 2019.

If additional information is required, contact Dale Richardson at 636-481-3501.

II. GENERAL SPECIFICATIONS

- Contractors must specify any deviation in specifications.
- The delivery and installation schedule shall be at the convenience of the College.
- Proposals must be completed on the form provided.
- Contractors must supply at least three references including name of company, contact person, telephone number and email address.
- The contract shall be AIA Form A105 Standard Form of Agreement between Owner and Contractor for Small Commercial Project.

III. SCOPE OF WORK

Jefferson College is soliciting proposals to lawfully replace and dispose of the roof and its materials on the Field House, Student Center, Child Development and Viking Woods Housing Building. (Buildings to be quoted separately.)

A. GENERAL SPECIFICATIONS – FIELD HOUSE AND STUDENT CENTER ROOF REPLACEMENT

1. Field House Roof

a) Main Roof:

1. Center area of the roof is a sloped tectum deck with approx. 3” total thickness comprised of two built up roofs separated by fiberglass insulation. Base sheet mopped directly to the tectum. Cores came up easily.
2. Remove all roofing down to tectum deck and provide unit cost to repair decking. Repairs should be from joist to joist with like material, assume 200 sq ft in base bid and indicate add or deduct amount for footage other than indicated.
3. Install wood nailers to accommodate new insulation heights. Replace any rotted or damaged existing nailers. Provide a per lineal foot unit cost for ALL nailer replacement of existing on all roof areas. Fasten all according to FM I-49 standards.
4. Install MB 120 base sheet over tectum deck, fastened with dual prong fasteners 9” oc in the laps with two staggered rows of 18” oc in the center.

5. Adhere R-30 polyiso, crickets, sumps and ½” coverboard in two part low rise foam, 6” oc in the field, 4” oc in the perimeter and corners.
6. Adhere new 060 EPDM non-reinforced with 3” factory applied seam tape.
7. Colledge to cover bleachers below to mitigate clean up after tear off.
8. Ensure positive drainage in all locations, ponding will be unacceptable. Utilize tapered drawing provided in this bid package only. No alternative layouts will be acceptable.
9. Install Versitrim roof edge according to detail shown.

b) Perimeter (rectangular) roofs on outside of expansion joint:

1. These 4 areas are sloped metal decks with two roofs comprised of BURs separated by fiberglass insulation, spot mopped to the deck.
2. Remove all roofing down to metal deck and inspect for deficiencies.
3. Install wood nailers to accommodate new insulation heights. Replace any rotted or damaged existing nailers. Fasten all according to FM I-49 standards.
4. Install R-30 polyiso, crickets, and drain sumps mechanically attached to the metal deck using 16 fasteners and plates per 4x8 board. Less fasteners may be utilized according to manufacturers’ recommendations IF pull tests indicate 425lbs+ of pull resistance.
5. Install ½” coverboard in 2 part low rise foam 6” oc in the field and 4” oc in the perimeter and corner areas.
6. Adhere new 060 EPDM non-reinforced with 3” factory applied tape.
7. Install Versitrim roof edge according to detail shown.

c) Corner Stair Well Roof Areas:

1. Concrete deck areas with no structural slope. Of the four roof areas, two are EPDM and two built up roof systems all approximately 3” thick. The EPDM roofs are spiked to the concrete, the built ups are spot mopped directly to deck.

2. Remove existing roof systems down to concrete deck and inspect for deficiencies. These areas should be torn of when forecast calls for clear skies for three days. At least two of them will need to dry out prior to new roof installation.
3. Install wood nailers to accommodate new insulation heights. Replace any rotted or damaged existing nailers. Fasten all according to FM I-49 standards.
4. Prime concrete deck with Cav-Grip primer and allow to dry prior to insulation adhesive application.
5. For these roof areas only, 4 way slope, ¼” incline SECURESHIELD tapered iso shall be installed in two part low rise foam adhesive 4” oc.
6. Install ½” coverboard in two part low rise foam 4” oc.
7. Adhere new 060 EPDM non-reinforced with 3” factory applied tape
8. Raised areas included, continue tapered on these areas and install termination bar on vertical face, both sides.

2. Student Center Roof

a) Student Center Upper Roof

1. Remove existing Built Up and tapered perlite down to concrete deck.
2. Install wood nailers to accommodate new insulation heights. Replace any rotted or damaged existing nailers. Fasten all according to FM I-49 standards.
3. Use Cav Grip primer on concrete deck prior to insulation adhesive application.
4. Install Secureshield, coated glass facer polyiso tapered as indicated on attached roof plan. Bead applied two part low rise foam adhesive 6” oc in the field, 4” oc in the perimeter .
5. Adhere ½” Securock coverboard 6”oc field and 4” oc perimeter.
6. Adhere new 060 Non Reinforced EPDM with pre applied tape
7. Install Versitrim roof edge according to detail shown.
8. Replace drains with new retrofit units.

b) Student Center Upper Roof Stair Tower

1. Remove built up and tapered perlite down to concrete deck
2. Install wood nailers to accommodate new insulation heights. Replace any rotted or damaged existing nailers. Fasten all according to FM I-49 standards.
3. Use Cav Grip primer on concrete deck prior to insulation adhesive application.
4. Install Secureshield, coated glass facer polyiso tapered as indicated on attached roof plan. Bead applied two-part low-rise foam adhesive 6" oc in the field, 4" oc in the perimeter.
5. Adhere ½" Securock coverboard 6"oc field and 4" oc perimeter.
6. Adhere new 060 Non Reinforced EPDM with pre applied tape
7. Install Versitrim roof edge according to detail shown, replace spill-out scupper.

c) Asbestos Abatement

1. The Student Center roof has been tested and the findings indicate the flashings contain asbestos. Abatement will be required by a certified abatement subcontractor of the awarded contractor and a certificate of the abatement issued.

Findings attached.

3. Notes

- a) All roof area edge metal to be Versitrim 2000, two piece fascia system covered in the roof system warranty as shown below:

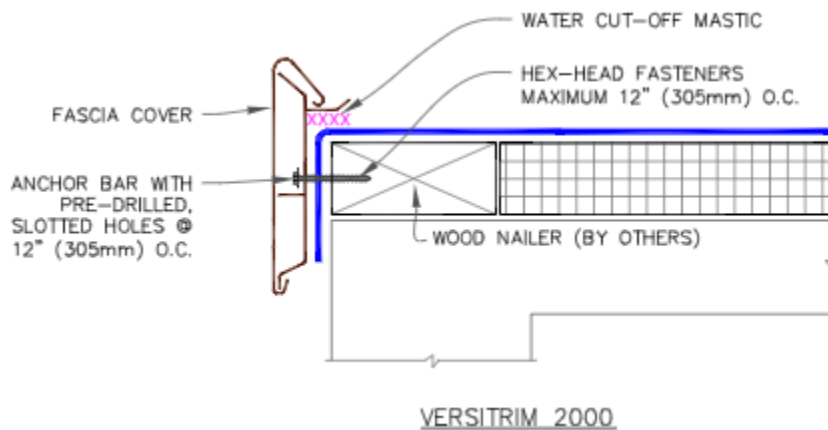

- b) Raised expansion joint details surrounding the main roof area to be detailed as shown:

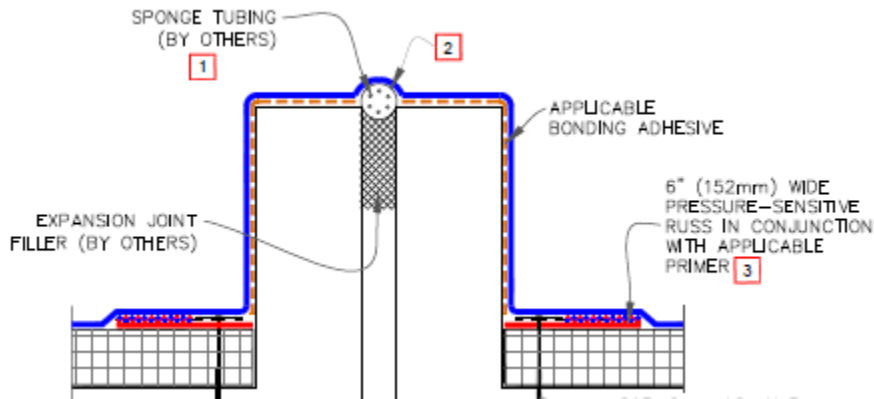

- c) All drains and overflows to be replaced with new retrofit units.
d) Provide Versico 20 year 72 mph Edge to Edge Warranty.
e) Project completion window to be (May 10 –July 26) and completion shall not extend past this date. For each day beyond this date, including sheet metal, the contractor shall incur liquidated damage penalties of \$1000 per day. Rain or inclement weather days will be granted and agreed upon by both parties, no exceptions.
f) Manufacturer to make a minimum of three site visits during installation.
g) Notify College one day prior to final inspection.

4. Alternates

- a) Price for 1000 sq ft of tuckpointing on Field House Roof areas, provide an add or deduct sq ft amount for more or less.
b) Lineal foot price for replacement of rotten or otherwise deteriorated existing nailers.
a. Include additional nailers to accommodate new insulation heights in base bid.

5. Specifications

1.1 SECTION 07540 - ADHERED EPDM MEMBRANE ROOFING

- A. Drawings and general provisions of the Contract apply to this Section.

1.2 SUMMARY

- A. This Section includes the following:
 - 1. Install new fully adhered .060 black non-reinforced EPDM over new insulation and coverboard.
 - 2. Provide and install new metal edges to be included in the roof warranty.
 - 3. Provide manufacturer's 20-year 72 mph system warranty.

1.3 DEFINITIONS

- A. Roofing terminology: Refer to ASTM D 1079 and glossary of NRCA's "The NRCA Roofing and Waterproofing Manual" for definition of terms related to roofing work in this Section.

1.4 SYSTEM PERFORMANCE REQUIREMENTS

- A. General: Install EPDM sheet membrane roofing and base flashings that remain watertight; do not permit the passage of water; and resist specified uplift pressures, thermally induced movement, and exposure to weather without failure.
- B. Material Compatibility: Provide roofing materials that are compatible with one another under conditions of service and application required, as demonstrated by roofing membrane manufacturer based on testing and field experience.
- C. UL Listing: Provide labeled materials, which have been listed in the UL "Roofing Materials Directory" as "Class A" rated materials and systems for all roof areas.

1.5 SUBMITTALS

- A. General Product Data: Specifications and performance criteria contained herein are based on current manufacturer's data and will be strictly enforced. Contractors shall submit with their bids, information supporting those criteria for physical properties of materials, application of materials, contractor and manufacturer's experience and warranty requirements outlined in this Section are met as specified.
- B. Shop Drawings: Roof configuration, sheet layout, details.
- C. Samples for Verification: For the following products:
 - 1. 4-by-4-inch (300-by-300-mm) square of sheet roofing, of color specified

2. 4-by-4-inch (300-by-300-mm) square of roof insulation.
 3. 4-by-4-inch (300-by-300-mm) square of walkway pads or rolls.
- D. Installer Certificates: Signed by roofing system manufacturer certifying that Installer is approved, authorized, or licensed by manufacturer to install roofing system.
 - E. Qualification Data: For Installer and manufacturer.
 - F. Product Test Reports: Based on evaluation of comprehensive tests performed by manufacturer and witnessed by a qualified testing agency, for components of roofing system.
 - G. Research/Evaluation Reports: For components of membrane roofing system.
 - H. Maintenance Data: For roofing system to include in maintenance manuals.
 - I. Warranties: Special warranties specified in this Section.
 - J. Inspection Report: Copy of roofing system manufacturer's inspection report completed roofing installation.

1.6 QUALITY ASSURANCE

- A. General: Perform Work in strict accordance with the manufacturer's latest standards and details. When project is complete, notify owner 48 hours prior to manufacturer's final inspection. All repairs necessary for the warranty will be made immediately thereafter.
- B. Installer Qualifications: A qualified firm that is approved, authorized, or licensed by roofing system manufacturer to install manufacturer's product and that is eligible to receive manufacturer's warranty and has been specializing in performing the work of this Section, with a minimum of 10 years documented experience. In addition, the contractor shall have at least 10 installations similar to the one specified with base manufacturer and must have had key personnel attend a quality control seminar hosted by the manufacturer in the past 12 months.
- C. Manufacturer Qualifications: A qualified manufacturer that has participated in the manufacture of specified products, with a minimum of 15 years documented experience and a UL listing for membrane roofing system identical to that used for this Product.
- D. Source Limitations: Obtain components for membrane roofing system from or approved by roofing membrane manufacturer.

- E. Fire-Test-Response Characteristics: Provide membrane roofing materials with the fire-test-response characteristics indicated as determined by testing identical products per test method below by UL, FMG, or another testing and inspecting agency acceptable to authorities having jurisdiction. Materials shall be identified with appropriate markings of applicable testing and inspecting agency.
 - 1. Exterior Fire-Test Exposure: Class A, ASTM E-108, for application and roof slopes indicated.

- F. Pre-installation Conference: Conduct conference at Project site. Comply with requirements in Division 1 Section "Project Meetings." Review methods and procedures related to roofing system including, but not limited to, the following:
 - 1. Meet with Owner, Owner's insurer if applicable, testing and inspecting agency representative, roofing Installer, roofing system manufacturer's representative, deck Installer, and installers whose work interfaces with or affects roofing, including installers of roof accessories and roof-mounted equipment.
 - 2. Review methods and procedures related to roofing installation, including manufacturer's written instructions.
 - 3. Review and finalize construction schedule and verify availability of materials, Installer's personnel, equipment, and facilities needed to make progress and avoid delays.
 - 4. Examine deck substrate conditions and finishes for compliance with requirements, including flatness and fastening.
 - 5. Review structural loading limitations of roof deck during and after roofing.
 - 6. Review base flashings, special roofing details, roof drainage, roof penetrations, equipment curbs, and condition of other construction that will affect roofing system.
 - 7. Review governing regulations and requirements for insurance and certificates if applicable.
 - 8. Review temporary protection requirements for roofing system during and after installation.
 - 9. Review roof observation and repair procedures after roofing installation.

1.7 DELIVERY, STORAGE, AND HANDLING

- A. Deliver roofing materials to Project site in original containers with seals unbroken and labeled with manufacturer's name, product brand name and type, date of manufacture, and directions for storing and mixing with other components.

- B. Store liquid materials in their original undamaged containers in a clean, dry, protected location and within the temperature range required by roofing system manufacturer. Protect stored liquid material from direct sunlight.

1. Discard and legally dispose of liquid material that cannot be applied within its stated shelf life.
- C. Protect roof insulation materials from physical damage and from deterioration by sunlight, moisture, soiling, and other sources. Store in a dry location. Comply with insulation manufacturer's written instructions for handling, storing, and protecting during installation.
- D. Handle and store roofing materials and place equipment in a manner to avoid permanent deflection of deck.

1.8 PROJECT CONDITIONS

- A. Weather Limitations: Proceed with installation only when existing and forecasted weather conditions permit roofing system to be installed according to manufacturer's written instructions and warranty requirements.
1. At ambient temperatures of 40 degrees F or below, including wind chill, cold adhesive shall be stored in warm location prior to immediate use (within 4 hours).

1.9 PROTECTION

- A. Protect surfaces adjacent to roofing work against staining or mechanical damage.

1.10 TOTAL SYSTEM WARRANTY

- A. Provide written warranty, signed by the manufacturer and backed by a certifiable warranty pool, agreeing to replace or repair defective materials and workmanship, covering all material and labor costs for a period of 20 years. This warranty shall have no monetary limit provisions and be enforceable to a wind speed of 72-miles per hour.

PART 2 – PRODUCTS

2.1 MANUFACTURERS

- A. Manufacturers: Subject to compliance with requirements, provide products by manufacturer specified.
1. Versico Roofing Systems – Versigard Fully Adhered Roof System.
 - a. Alternate equal systems will be reviewed by Jefferson College no later than ten days prior to bid.

- b. Requirements for Alternate roof system proposals:
 - i. Submit Technical data sheets for ALL products listed in this specification, highlight specific products and dimensions.
 - ii. Provide letter from proposed manufacturer stating products and systems submitted will qualify for warranty specified.
 - iii. Provide documentation contractor meets criteria set forth in section 1.6 B

2.2 EPDM ROOFING MEMBRANE

- A. Non-Reinforced Fire Rated EPDM Sheet: Uniform, flexible sheet formed from EPDM polymers as follows:

- 1. Thickness 60 mils, nominal.
- 2. Exposed Face Color: Black
- 3. Factory applied 3" seam tape

2.3 AUXILIARY MATERIALS

- A. General: Auxiliary materials recommended by roofing system manufacturer for intended use and compatible with membrane roofing.

Liquid-type auxiliary materials shall meet VOC limits of authorities having jurisdiction.

- B. Sheet Flashing: Manufacturer's standard sheet flashing of same material, type, thickness and color of sheet membrane.
- C. Bonding Adhesive: Manufacturer's spray applied, single component adhesive.
- D. Expansion Joints (Detail as standard of the manufacturer).
- E. Bellow Cover Sheet: Membrane as standard of the manufacturer for this application.
- F. Compressible Tube: Compressible Tube diameter must equal or exceed the deck opening. Provide enough membrane around tube to allow for anticipated expansion.

2.4 METAL TERMINATION SYSTEMS

- A. Provide items specified below where applicable and in accordance with the drawings.

1. Versitrim as noted in scope
2. Metal to be included in the roof system manufacturers Edge to Edge Total System Warranty.

2.5 ROOF INSULATION

- A. General: Provide Polyisocyanurate Insulation with ASTM 1289 designation, Type II, Class 1, Grade 2 (20 psi) supplied by the manufacturer of the roofing membrane system, of thicknesses required to achieve R-30 in all locations using flat insulation and an average where tapered insulation is required per International Building Code 2015 (Adopted by Jefferson County). ½” per foot slope crickets to provide positive drainage where indicated on tectum, steel and concrete decks.
- B. Provide SECURESHIELD Type II, Class 2, Grade 2, ¼” per foot slope tapered roof insulation adhered to concrete deck areas only. ½” per foot for crickets.

2.6 COVER BOARD

- A. Gypsum fiber cover board approved by roof system manufacturer, designed to be used in fully adhered roof system applications.
- B. ½” Thick, 1800 psi minimum

2.7 WALKWAY PADS

- A. Walkway Pads: Factory applied adhesive tape designed for use on EPDM systems. Install at all roof entry and egress points, around serviceable roof top units and where otherwise noted.

PART 3 - EXECUTION

3.1 EXAMINATION

- A. Examine substrates, areas, and conditions, with Installer present, for compliance with the following requirements and other conditions affecting performance of roofing system.
 1. Verify that roof openings and penetrations are in place and set and braced and that roof drains are securely clamped in place.
 2. Verify that new wood blocking, curbs, and nailers are securely anchored to roof deck at penetrations and terminations and that nailers match

thicknesses of insulation and are appropriate thicknesses to accommodate new metal edge.

3.2 PREPARATION

- A. Clean substrate of dust, debris, moisture, and other substances detrimental to roofing installation according to roofing system manufacturer's written instructions. Remove sharp projections.
- B. Prevent materials from entering and clogging roof drains and conductors and from spilling or migrating onto surfaces of other construction. Remove roof-drain plugs when no work is taking place or when rain is forecast.
- C. Dispose of debris and roofing materials in accordance with local and federal guidelines.
- D. Complete the terminations and base flashings and provide temporary seals to prevent water from entering completed sections of roofing system at the end of the workday or when rain is forecast. Remove and discard temporary seals before beginning work on adjoining roofing.

3.3 INSULATION INSTALLATION

- A. Prime all decks with Cav Grip where insulation is to be directly adhered. No roller applied primer will be accepted.
- B. Adhere insulation to base sheet and concrete deck, minimum 6" oc field, 4" oc perimeter and corners, using two-part low-rise foam adhesive, per manufacturer's requirements to meet warranty specified.
- C. Follow included tapered insulation design where indicated and ensure there are no ponding areas or impediments to drainage.
- D. Coordinate installing membrane roofing system components so insulation is not exposed to precipitation or left exposed at the end of the workday.
- C. Comply with membrane roofing system manufacturer's written instructions for installing roof insulation.
- D. Install all layers - staggered joints under area of roofing to conform to slopes indicated.
- E. Install one or more layers of insulation under area of roofing to achieve required thickness. Where overall insulation thickness is 2.6 inches or greater, install 2 or more layers with joints of each succeeding layer staggered from joints of previous layer a minimum of 6 inches (150 mm) in each direction.

- F. Trim surface of insulation where necessary at roof drains so completed surface is flush and does not restrict flow of water.
- G. Install insulation with long joints of insulation in a continuous straight line with end joints staggered between rows, abutting edges and ends between boards. Fill gaps exceeding ¼-inch insulation.
- G. Cut and fit insulation within ¼ inch (6 mm) of nailers, projections, and penetrations. Adhere insulation according to the insulation and roofing system manufacturer's written instructions.

3.4 COVER BOARD INSTALLATION

- E. Fully Adhered cover board in two part low rise foam, bead applied (min 6" oc field, 4" oc perimeter and corners)

3.5 ADHERED EPDM ROOFING MEMBRANE INSTALLATION

- A. Install EPDM sheet over area to receive roofing according to roofing system manufacturer's written instructions. Adhere membrane on all roof areas using largest sheet practical for job conditions. Avoid wrinkling or stretching the membrane. Unroll sheet and allow relaxing for a minimum of 30 minutes.
- B. Start installation of roofing membrane in presence of membrane roofing system manufacturer's technical personnel.
- C. Accurately align roofing membrane and maintain uniform side and end laps of minimum dimensions required by manufacturer. Stagger end laps.
- D. Bonding Adhesive: Apply bonding adhesive to substrate and underside of roofing membrane at rate required by manufacturer and allow to partially dry before installing roofing membrane. Do not apply bonding adhesive to splice area of roofing membrane.
- E. Mechanically fasten roofing membrane securely at terminations, penetrations, angle changes and perimeter of roofing.
- F. Apply roofing membrane with side laps shingled with slope of roof deck where possible.
- G. Seams: Clean seam areas, overlap roofing membrane, tape side and end laps of roofing membrane according to manufacturer's written instructions to ensure a watertight seam installation.
 - 1. Test lap edges to verify seam strength.

2. Apply lap sealant to seal all edges of flashing membrane and T-Patches.
 3. Repair tears, voids, and lapped seams in roofing membrane that do not meet requirements.
- H. Spread sealant or mastic bed over deck drain flange at deck drains and securely seal roofing membrane in place with clamping ring.

3.6 FLASHING INSTALLATION

- A. Install manufacturer's standard materials.
- B. Incorporate factory fabricated accessories whenever possible.
- C. Terminate membrane with products included in the warranty.
- D. Install sheet flashings and preformed flashing accessories and adhere to substrates according to membrane roofing system manufacturer's written instructions.
- E. Apply bonding adhesive to substrate and underside of sheet flashing at required rate and allow to partially dry. Do not apply bonding adhesive to seam area of flashing.
- F. Flash penetrations and field-formed inside and outside corners with sheet flashing.
- G. Clean seam areas and overlap and firmly roll sheet flashings into the adhesive. Tape side and end laps to ensure a watertight seam installation.
- H. Test lap edges to verify seam strength. Apply lap sealant and seal exposed edges of sheet flashing terminations.
- I. Terminate and seal top sheet flashings and mechanically anchor to substrate through termination bars.

3.7 WALKWAY PAD INSTALLATION

- A. Walkways: Clean, Prime and install walk pads with factory applied seam tape where noted.

3.8 FIELD QUALITY CONTROL

- A. Verify field strength of seams as often as required and in accordance with the roofing system manufacturer's instructions, are repair seam sample areas.

- B. Final Roof Inspection: Arrange for roofing system manufacturer's technical personnel to inspect roofing installation on completion.
 - 1. Notify Owner 48 hours in advance of date and time of inspection.
- C. Repair or remove and replace components of membrane roofing system where test results or inspections indicate that they do not comply with specified requirements.
- D. Additional testing and inspecting, at Contractor's expense, will be performed to determine compliance of replaced or additional work with specified requirements.

3.9 PROTECTING AND CLEANING

- A. Protect membrane roofing system from damage and wear during remainder of construction period. When remaining construction will not affect or endanger roofing, inspect roofing for deterioration and damage, describing its nature and extent in a written report, with copies to Owner.
- B. Correct deficiencies in or remove membrane roofing system that does not comply with requirements, repair substrates, and repair or reinstall membrane roofing system to a condition free of damage and deterioration at time of Substantial Completion and according to warranty requirements.
- C. Clean overspray and spillage from adjacent construction using cleaning agents and procedures recommended by manufacturer of affected construction.

B. GENERAL SPECIFICATIONS – CHILD DEVELOPMENT AND VIKING WOODS HOUSING ROOF REPLACEMENT

1. Child Development and Viking Woods Housing

- a) Asphalt fiberglass shingles.
 - 1. Lawfully remove and replace shingles and materials.
 - 2. Remove, replace, and store shingles in accordance with manufacturer's instruction for product type and application specified.
 - 3. No overlay.

4. Acceptable shingles to be Certain Teed Landmark AR or Approved equal conforming to ASTM D 3018 type 1- self-sealing, UL Certification of ASTM D 3462, ASTM D 3161/UL997 110 mph wind resistance and UL class A fire resistance, glass fiber mat base, ceramically colored/UV resistant mineral surface granules across entire face of shingle, algae-resistance, two-piece laminate shingle.
 5. Color of shingles to be picked out by Buildings and Grounds Director.
- b) Accessories
1. Asphalt roofing cement to be ASTM D 4586, type 1 or 2 (or comparable)
 2. Nails to be standard round wire type roofing nails, corrosion resistant, hot dipped zinc coated steel, aluminum or chromated steel, minimum 3/8inch head diameter, minimum 11 or 12 gage shank diameter, shank to be sufficient length to penetrate through the roof sheathing or 3/4 inch into solid wood, plywood or non-veneer wood decking.
- c) Underlayment
1. Remove and replace damaged plywood as needed.
 2. Waterproofing underlayment: Certain Teed “winterguard”, or approved equal conforming to ASTM D 1970 sheet barrier of self-adhering rubberized asphalt membrane shingle underlayment having internal reinforcement, and split back plastic release film.
 3. Second layer of underlayment to be ASTM D 226 asphalt saturated felt (non-perforated) (or comparable).

d) Warranty (alternate)

1. Certain Teed Landmark AR: lifetime limited warranty, option for 5-star coverage or approved equal.

e) Drip Edge Requirements

1. Provide and install a drip edge so that water is diverted into guttering system.

IV. COMMENCING AND COMPLETION OF WORK

This project is subject to the Jefferson College Board of Trustees approval of funding on May 9, 2019. Work to be performed during the hours of 7:00 a.m. – 4:30 p.m. Monday through Friday, May 10-July 26, 2019. Completion shall not extend beyond this date.

V. PROJECT ADMINISTRATION

The College Director of Buildings and Grounds shall be the College's representative on the project. The Director shall have the sole authority, after consultation with College Officials, to approve any changes in the scope of the project, specifications or other matters relative to the project.

**Dale Richardson
Jefferson College
1000 Viking Drive
Hillsboro, MO 63050
Telephone: 636-481-3501
Email: drichar6@jeffco.edu**

VI. INSURANCE AND BONDS

- A. Each proposal shall be accompanied by a five percent bid bond from a bonding company satisfactory to the Community College District of Jefferson County. Proposal security is required as guarantee that contractor will enter into a written contract and furnish performance and payment bonds; and if successful contractor fails to do so within 30 days from the date of closing of the proposals, proposal security will be called in by the College.

- B. The successful contractor shall furnish a performance and payment bond for 100 percent of the completed contract amount as security for the faithful performance of the contract.
- C. The successful contractor shall submit to the College a “Certificate of Insurance” for all insurance required under this provision. The contractor shall provide and maintain in effect during the life of the project and warranty period the following coverage, **for which Jefferson College shall be named as “an additional insured”**.

Worker’s compensation Statutory limits

Comprehensive general liability
(including premises-operations;
Independent contractors’ protective;
Products and completed operations;
Broad form property damage):

Bodily injury:

Each occurrence	\$ 500,000
Aggregate, products And completed operations	\$1,000,000

Property damage:

Each occurrence	\$ 500,000
Aggregate	\$1,000,000

Products and completed operations
Insurance shall be maintained for
The duration of construction and
Contractor shall continue to
Provide evidence of such coverage to
College during the construction period.

Property damage liability insurance
Shall include coverage for the
Following hazards:

Explosion
Collapse
Underground

Contractual liability:

Bodily injury	\$ 500,000
Property damage	\$ 500,000

Comprehensive automobile liability:
(owned, non-owned, and hired)

Bodily injury:	
Each person	\$ 500,000
Each accident	\$1,000,000
Property damage	\$1,000,000

VII. PREVAILING WAGES

This project shall require that not less than the prevailing hourly rate of wages in the County of Jefferson, as determined by the Missouri Department of Labor Relations for each craft and type of worker required. Compliance of all sections of 290.250 and other applicable sections of the revised statutes of the state of Missouri is mandatory.

The contractor shall submit a copy of the affidavit of compliance, as submitted to the state of Missouri, to Jefferson College with the final invoice for payment.

The contractor shall post the prevailing hourly wage rates on the project site.

The contractor shall complete and submit to the owner with each request for payment, a certified copy of the payroll records for all workers involved on this project.

The contractor shall complete and submit to the owner upon completion of the project, the affidavit of compliance and the contractor’s report of construction wages with the final invoice. Copies of these forms are provided with this document.

The contractor shall forfeit as a penalty, one hundred dollars for each worker employed, for the calendar day or portion thereof such worker is paid less than the stipulated wage rate, or the applicable penalty as set forth by the Missouri division of labor relations.

The contractor shall cause a statement to be written into the performance bond that guarantees the faithful performance of the prevailing hourly wage rate, as stipulated by the Missouri Division of Labor Relations.



**DIVISION OF
LABOR
STANDARDS**

MISSOURI DEPARTMENT OF LABOR AND INDUSTRIAL RELATIONS
DIVISION OF LABOR STANDARDS
**AFFIDAVIT
COMPLIANCE WITH THE PREVAILING WAGE LAW**

I, _____, upon being duly sworn upon my oath state that: (1) I am the
(Name)
_____ of _____; (2) all requirements of
(Title) *(Name of Company)*
§§ 290.210 to 290.340, RSMo, pertaining to the payment of wages to workers employed on public works projects
have been fully satisfied with regard to this company's work on _____;
(Name of Project)

(3) I have reviewed and am familiar with the prevailing wage rules in 8 CSR 30-3.010 to 8 CSR 30-3.060; (4) based upon my knowledge of these rules, including the occupational titles set out in 8 CSR 30-3.060, I have completed full and accurate records clearly indicating (a) the names, occupations, and crafts of every worker employed by this company in connection with this project together with an accurate record of the number of hours worked by each worker and the actual wages paid for each class or type of work performed, (b) the payroll deductions that have been made for each worker, and (c) the amounts paid to provide fringe benefits, if any, for each worker; (5) the amounts paid to provide fringe benefits, if any, were irrevocably paid to a trustee or to a third party pursuant to a fund, plan, or program on behalf of the workers; (6) these payroll records are kept and have been provided for inspection to the authorized representative of the contracting public body and will be available, as often as may be necessary, to such body and the Missouri Department of Labor and Industrial Relations; (7) such records shall not be destroyed or removed from the state for one year following the completion of this company's work on this project; (8) when in effect, the requirements of §§ 290.550 through 290.580, RSMo, pertaining to excessive unemployment were fully satisfied; and (9) there has been no exception to the full and complete compliance with the provisions and requirements of Annual Wage Order No. _____ Section _____ issued by the Missouri Division of Labor Standards and applicable to this project located in _____ County, Missouri, and completed on the ____ day of _____, _____.

The matters stated herein are true to the best of my information, knowledge, and belief. I acknowledge that the falsification of any information set out above may subject me to criminal prosecution pursuant to §§290.340, 570.090, 575.040, 575.050, or 575.060, RSMo.

Signature

Subscribed and sworn to me this ____ day of _____, _____.
My commission expires _____, _____.

Notary Public

Receipt by Authorized Public Representative



**DIVISION OF
LABOR
STANDARDS**

MISSOURI DEPARTMENT OF LABOR AND INDUSTRIAL RELATIONS
CONTRACTOR PAYROLL RECORDS
(See Sections 290.210 to 290.340, RSMo and 3 CSR 30-3.010 to 8 CSR 30-3.060)

Name of Contractor Subcontractor

Name of Public Body

Address: _____ State: _____ ZIP: _____ Phone Number: () - _____

Address: _____ State: _____ ZIP: _____ Phone Number: () - _____

Payroll No.: _____ For Week Ending: / _____ Project and Location: _____ Project or Contract No.: _____

Name and Address of Employee	Occupational Title ***	Day and Date	Total Hours	Hourly Rate of Pay	Gross Amt Project/Week	Deductions			Net Wages Paid for Week
						FICA & Medicare	Federal & State Withholding Tax	Other	

*** If a worker performs work in more than one occupational title, you must separately list the hours worked per occupational title and wage rates. ***

VIII. INDEMNITY

Contractor agrees to indemnify and hold harmless the Community College District of Jefferson County and its directors, officers, employees, and agents from and against any and all liabilities, losses, damages, costs and expenses of any kind (including, without limitation, reasonable legal fees and expenses in connection with any investigative, administrative, or judicial proceeding, whether or not designated a party thereto) which may be suffered by, incurred by or threatened against the College or directors, officers, employees or agents of the College on account of or resulting from injury or claim of injury to person or property arising from Contractor's actions or omissions relating to this Agreement or arising out of Contractor's breach or failure to perform any term, covenant, condition, or agreement herein provided to be performed by the Contractor.

IX. WARRANTIES

Contractor shall guarantee workmanship for a period of one year after the date of substantial completion as determined by the College and contractor. Material warranties will be the maximum offered by the manufacturer at a minimum of a commercial 20-year warranty.

X. LIQUIDATED DAMAGES

Time is of the essence on this contract. Should the Contractor fail to finish the work on or before July 26, 2019. Contractor shall be charged by the College, as liquidated and ascertained damages, the sum of **One Thousand Dollars (\$1,000.00) for each calendar day** that the work remains incomplete beyond the specified date(s), subject only to extensions of time granted in writing by the College for unforeseen conditions. The amount so charged shall be deducted by the College from any monies which otherwise be or become payable to the Contractor.

XI. GUIDELINES

1. All workmanship must be in a professional manner and performed in a timely manner. Scheduling of work shall be coordinated with the Director of Buildings and Grounds.
2. The normal activities of the College will be ongoing and must not be interrupted by these projects.

3. Loud conversations, playing music, foul language, less than professional conduct by the contractor's workers will not be tolerated.
4. Parking, off-loading of materials and storage of tools and/or materials shall be coordinated with the Director of Buildings and Grounds.
5. Disposal of used materials from the project must be in a lawful manner and college dumpsters will not be used by the contractor or their workers, unless authorized by the Director of Buildings and Grounds.
6. Restrooms are available to the contractor's workers in the buildings.
7. Electric and other utilities in the buildings are available to the contractor.
8. The job site must be cleaned up each evening and before leaving for the weekend.
9. Parking for the contractor's workers shall be coordinated with the College staff.
10. Dumpster locations shall be coordinated with the Director of Buildings & Grounds.
11. The use of all tobacco and smoke-related products is prohibited on all properties owned or leased by Jefferson College, including buildings, facilities, and student housing, as well as outdoor areas such as sidewalks, parking lots, athletic fields, and common areas. The goal of the policy is to promote a healthy environment for all who utilize the College and its facilities.

PROPOSAL FORM
JEFFERSON COLLEGE
RFP #1904001
ROOF REPLACEMENT
DUE: APRIL 26, 2019
NOT LATER THAN 2:00 P.M.

A. FIELD HOUSE ROOF REPLACEMENT \$ _____

B. STUDENT CENTER ROOF REPLACEMENT \$ _____

ALTERNATES:

**COST FOR 1000 SQ FT OF TUCKPOINTING
ON FIELD HOUSE ROOF** \$+/- _____/SQ FT

**LINEAL FOOT PRICE FOR REPLACEMENT
OF ROTTEN OR DETIORATED EXISTING
NAILERS** \$ _____/L FT

C. CHILD DEVELOPMENT ROOF
REPLACEMENT \$ _____

D. VIKING WOODS HOUSING ROOF
REPLACEMENT \$ _____

ALTERNATE:

**COST FOR CERTAIN TEED LANDMARK AR:
LIFETIME LIMITED WARRANTY, OPTION
FOR 5-STAR COVERAGE OR APPROVED
EQUAL** \$ _____

SIGNATURE: _____

DATE: _____

PRINTED NAME: _____

PHONE: _____

COMPANY: _____

ADDRESS: _____

EMAIL ADDRESS: _____

REFERENCES

Company

Contact

Telephone/Email

Address

Company

Contact

Telephone/Email

Address

Company

Contact

Telephone/Email

Address